

■ Mechanically actuated clutches

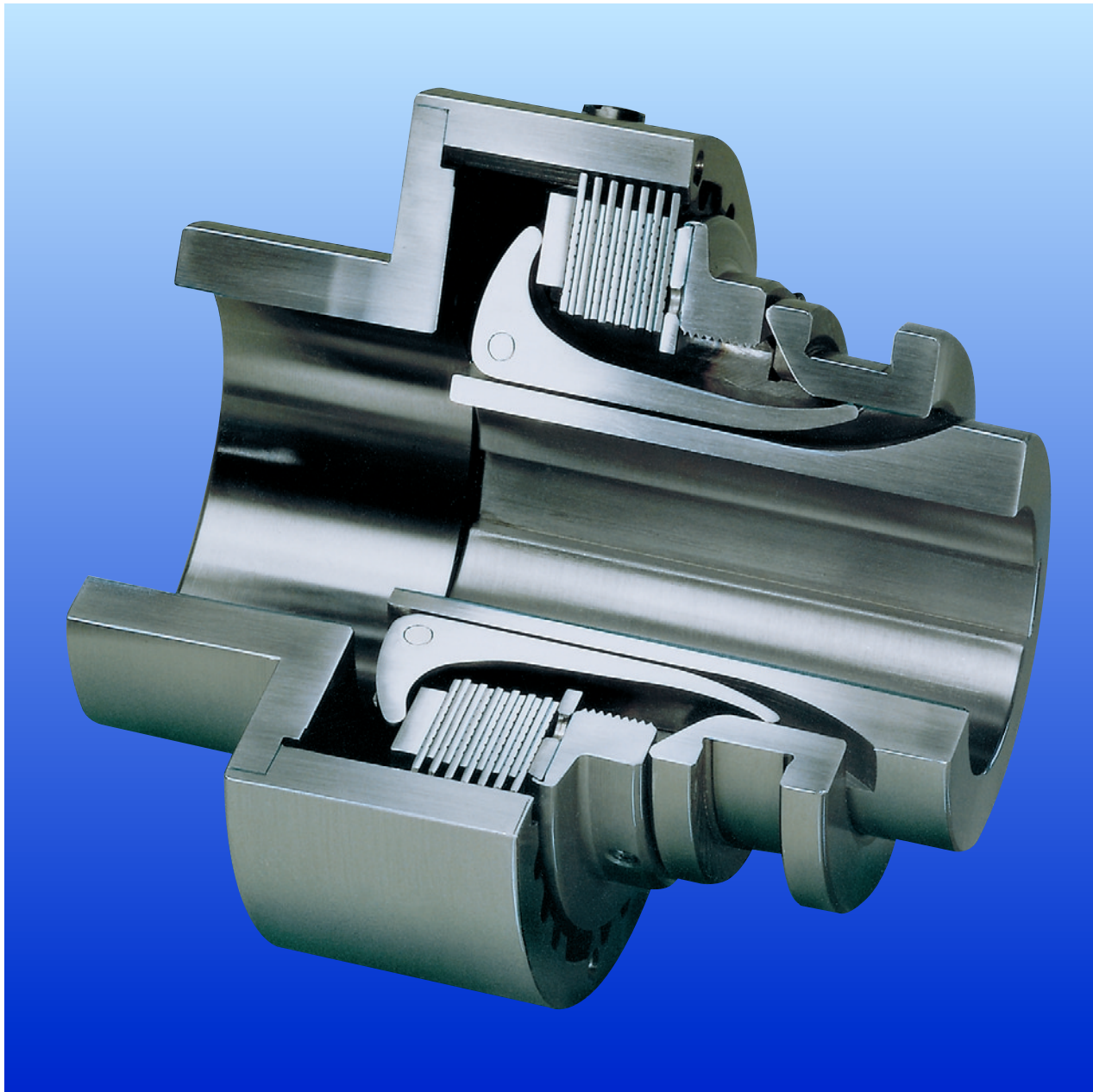

■ Mechanically actuated clutches

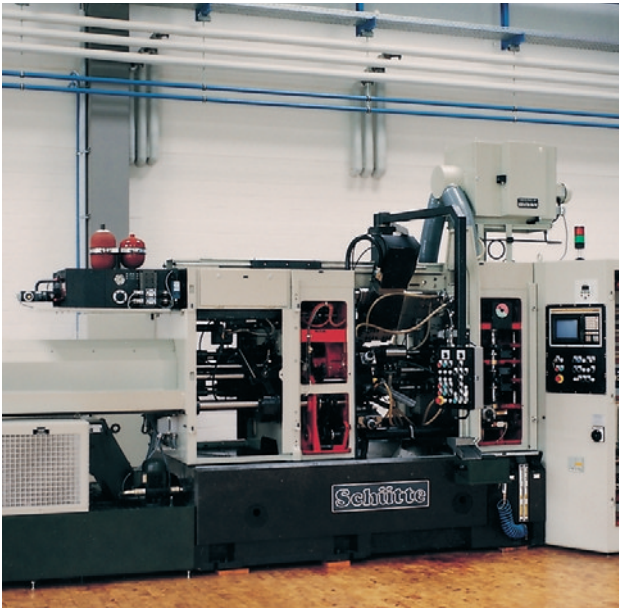

For many years Ortlinghaus mechanical clutches have been extremely popular and problem free. They offer a free choice in terms of the selection of the friction combination and the method of generating the engagement force.

They are supplied with the friction combinations steel/steel, steel/sintered lining and steel/organic lining and as a result are suitable for wet-running and dry-running, i.e. they can be used in either an open design or a closed design.

Engagement and disengagement of the clutches is by means of a „sliding sleeve“ with a cam profile which is moved axially over resilient angle levers, these in turn transmit the required force to the set of plates. A limited amount of plate wear is compensated for by the resilient bending of the levers so that the torque capable of being transmitted remains constant to a large extent and adjustment is only necessary after an extended period of time. The engaging/disengaging movement can be introduced by means of hand levers, pneumatic or hydraulic cylinders or electromechanical actuation systems.

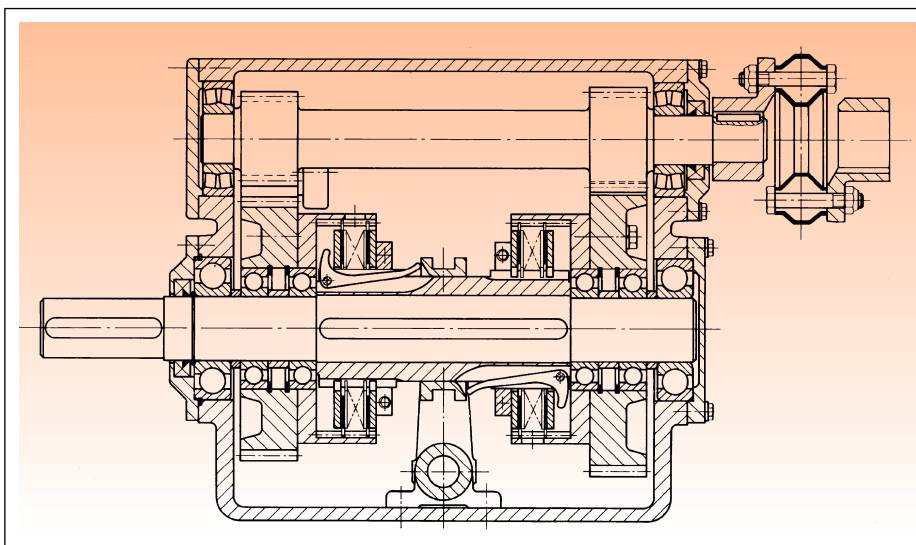

Fitting example

Mechanically actuated Ortlinghaus Sinus® multiplate double clutch and a highly elastic coupling fitted in a marine reversing gear.

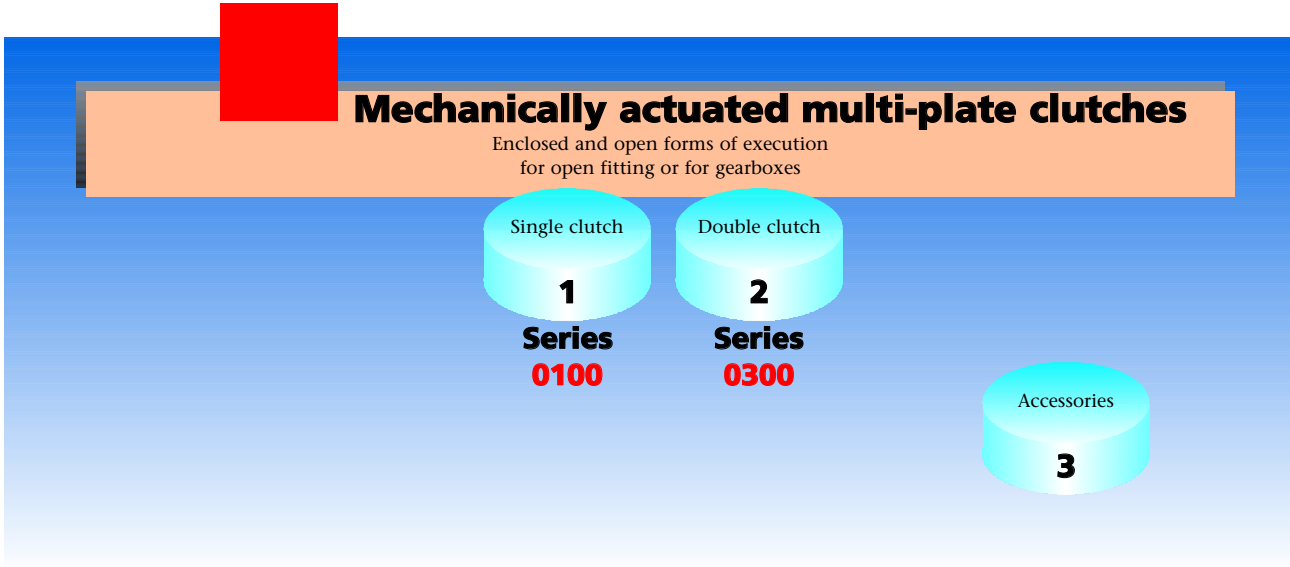

Mechanically actuated multi-plate clutches for wet- and dry-running

1/2 Series 0100 and 0300

The many different design variations of the plate stack, driving housing and actuating elements, makes this clutch versatile for all applications. They are to be found in the transmission systems of construction and agricultural machines. As a double clutch on one common clutch hub, they can be used, for example, to permit a speed change or one of the two sides can be used as a brake.

3 Accessories

We can supply the following accessories for manual actuation of the clutches:

- Actuation rings which surround the sliding sleeve.
- Hand levers
- Sliding blocks of steel or bronze

These elements can also be used as the basic elements when designing hydraulic, pneumatic or electromechanical operating systems.

No.	Series	Torque range Nm	Hub bore mm	Outside diam. mm
1/2	0100- a. 0300-000/-001	20 to 5300	10 to 130	70 to 435
	-002/-003	900 to 5300	28 to 130	210 to 435
	-004/-005	20 to 1400	10 to 80	65 to 260
	-006/-007	20 to 1400	10 to 80	65 to 260