

■ Electromagnetically actuated clutches and brakes

clutch / brake combined units, tooth clutches and spring-applied brakes

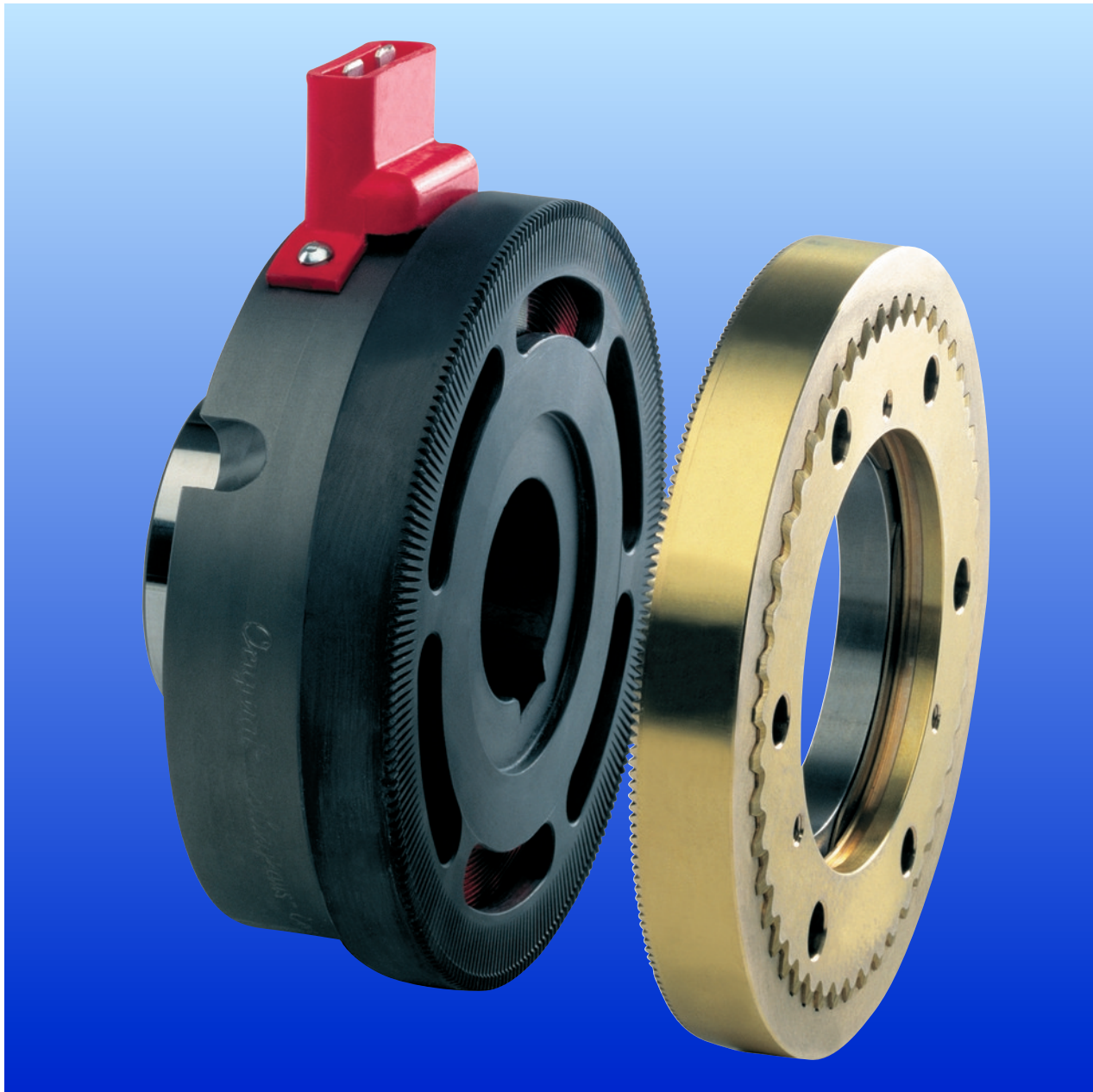

**Ortlinghaus – Plates.
Clutches. Brakes. Systems.**

■ Electromagnetically actuated clutches and brakes, clutch/brake combined units and tooth clutches



Thanks to the many design variations, Ortlinghaus electromagnetic clutches and brakes can be used in many different applications. The electromagnet with its built in coil is an actuation unit that is totally free of wear. The operating voltage, normally 24V DC, can usually be made available and introduced into the clutch or brake without any problem.

The engagement, or disengagement, can be adjusted and controlled electrically.

The areas of application of this product group are indicated with the aid of a number of examples. You will find further details in the sections describing the individual products.

Multi-plate clutches and brakes (1, 2, 3, 4, 5) are used in the main and secondary drives of machine tools, speed change gearboxes and in general mechanical engineering.

Single face clutches and brakes, combined units (6, 7, 8, 9, 10) are used in secondary drives, for example, on the front power take off shafts of agricultural tractors. In addition they are frequently used in packing, textile machines, and on conveyor belts. The product range gives the development engineer the freedom to tackle an almost unlimited range of applications.

Tooth clutches (11, 12) are the preferred clutch for printing machines; in addition they are used in, for example, turnstiles at public entrances and on drives for gates.

Spring-applied multi-plate brakes (13, 14) are used as safety brakes on, for example, cranes, winches and other lifting devices.

Spring-applied twin face brakes (15, 16) are used primarily for flanging directly onto electric motors.

Stationary field Sinus® multi-plate clutches for wet-running with flux through the plates design

1 Series 0010/0810

This is a powerful clutch requiring no maintenance for a wide spectrum of applications in mechanical engineering.

Friction combination: Wet-running steel plates which show little wear when properly cooled; no adjustment of the air gap required.

Power feed: Without slipping via cable and flat plug

Slipping Sinus® multi-plate clutches for wet-running with flux through the plates design

2/3 Series 0011-05. and 0011-100

A compact, maintenance free clutch for mechanical engineering applications providing high performance with small dimensions.

Available in both hub and housing versions, allowing application flexibility.

Friction combination: Wet-running steel plates which show little wear when properly cooled; no adjustment of the air gap required.

Power feed: Via slipping and brushes.

Sinus® multi-plate brakes for wet-running with flux through the plates design

4 **Series 0011-300**

Maintenance free, compact machine and transmission brake providing high performance with small dimensions.
 Friction combination: Wet-running steel plates which show little wear when properly cooled; no adjustment of the air gap required.
 Power feed: Via cables to terminals on the magnet body.

Slipring Sinus® multi-plate clutches for wet- or dry-running with adjustable air gap.

5 **Series 0006**

Friction combination: Steel/sinter for wet-running steel/sinter and steel/organic friction lining for dry-running. The magnetic flux does not flow through the plate stack, therefore there is no restriction on the friction combination that can be used.
 Power feed: Via sliprings and brushes.

Single face clutches and brakes for dry-running

6/7/8 **Series 0008-10./-30. and 0009 0808-10./-30. and 0809**

Magnetically actuated, rapid switching dry-running clutches and brakes for machines and many other devices. Both the clutches and the brakes permit space saving, adaptable to different design situations.
 When disengaged, these clutches and brakes are free of residual torque. They can be supplied either with magnet bodies in a mounted version with bearings or flange fixings to the machine frame. In the case of the brakes the magnet body also forms the pole friction surface, giving an especially short overall length. The armature plate can be connected to the relevant rotors in many different ways.
 Power feed: Via cables to the non-rotating magnet body.

Single face clutch/brake combined units

9/10 **Series 0008-102 and 0081**

Supplied ready to install, these space saving combined units of clutch and brake, series 0-008 and 0-009, offer all the advantages of this type of design. These combined units have proved

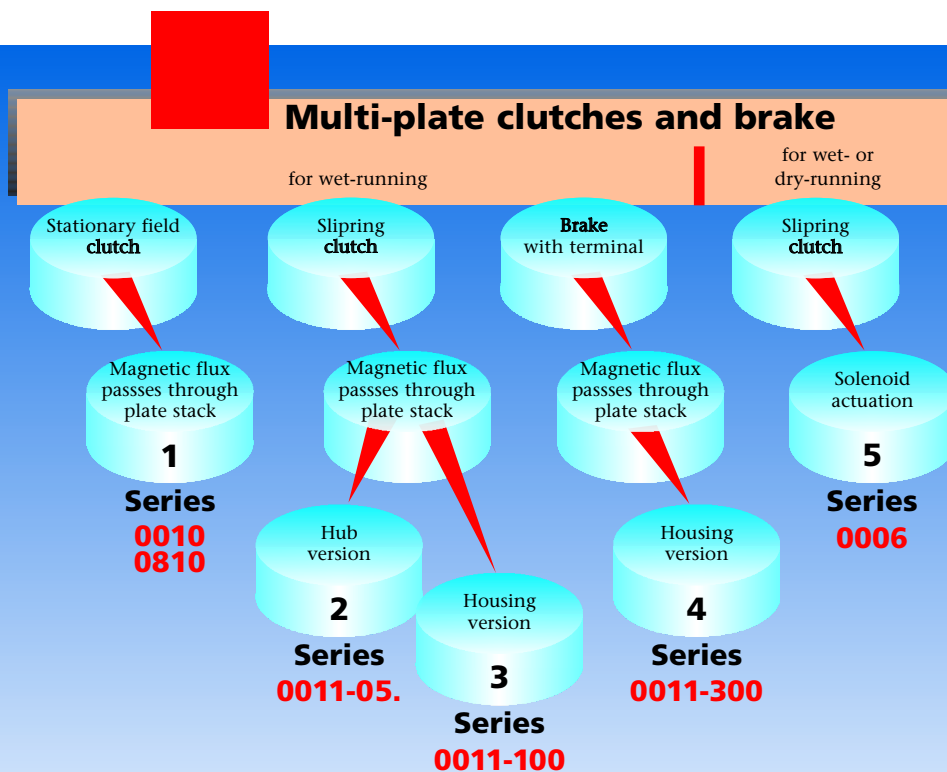

themselves especially suitable for drives in which the sequence of clutch disengagement/engagement and braking must be carried out continuously, rapidly and precisely. In addition to an open version (0008-102), a unit in a closed housing is also available (0081). The latter permits foot mounting and connection via shaft journals. Power feed: With 0-008-102 via cables to the non rotating magnet body; with 0081 to a terminal box on the housing.

Tooth clutches with and without slipping for wet- and dry-running

11/12 Series 0012/0812 and 0013/0813

Non-slip, compact clutches with teeth for the transmission of high torques in small spaces. This type of clutch is the correct choice when static engagement only, is required. Engaging at low speeds can also be carried out subject to particular electrical measures being taken. There is no residual torque when the clutch is disengaged. Power feed: In the case of 0012 via slipping and brushes. In the case of 0013 via cables and rectangular connectors.

Spring-applied multi-plate brake for wet- or dry-running

13/14 Series 0028 and 0228

The dry-running version is an electromagnetically released multi-plate brake that can be mounted as required. Special options: Dust cover, closed plate chamber; manual release lever for emergencies; version for wet-running. Friction combination: Steel/organic friction lining for dry-running or steel/brass for wet-running. Power feed: Either via cables and rectangular connectors (24 V DC) or to a connection box with integrated rectifier (220 V)

Spring-applied twin-face brakes for dry-running

15/16 Series 0207

This brake is particularly suitable for mounting on electric motors. In addition to the standard version, a central torque setting facility is available, together with dust protection and manual release lever.

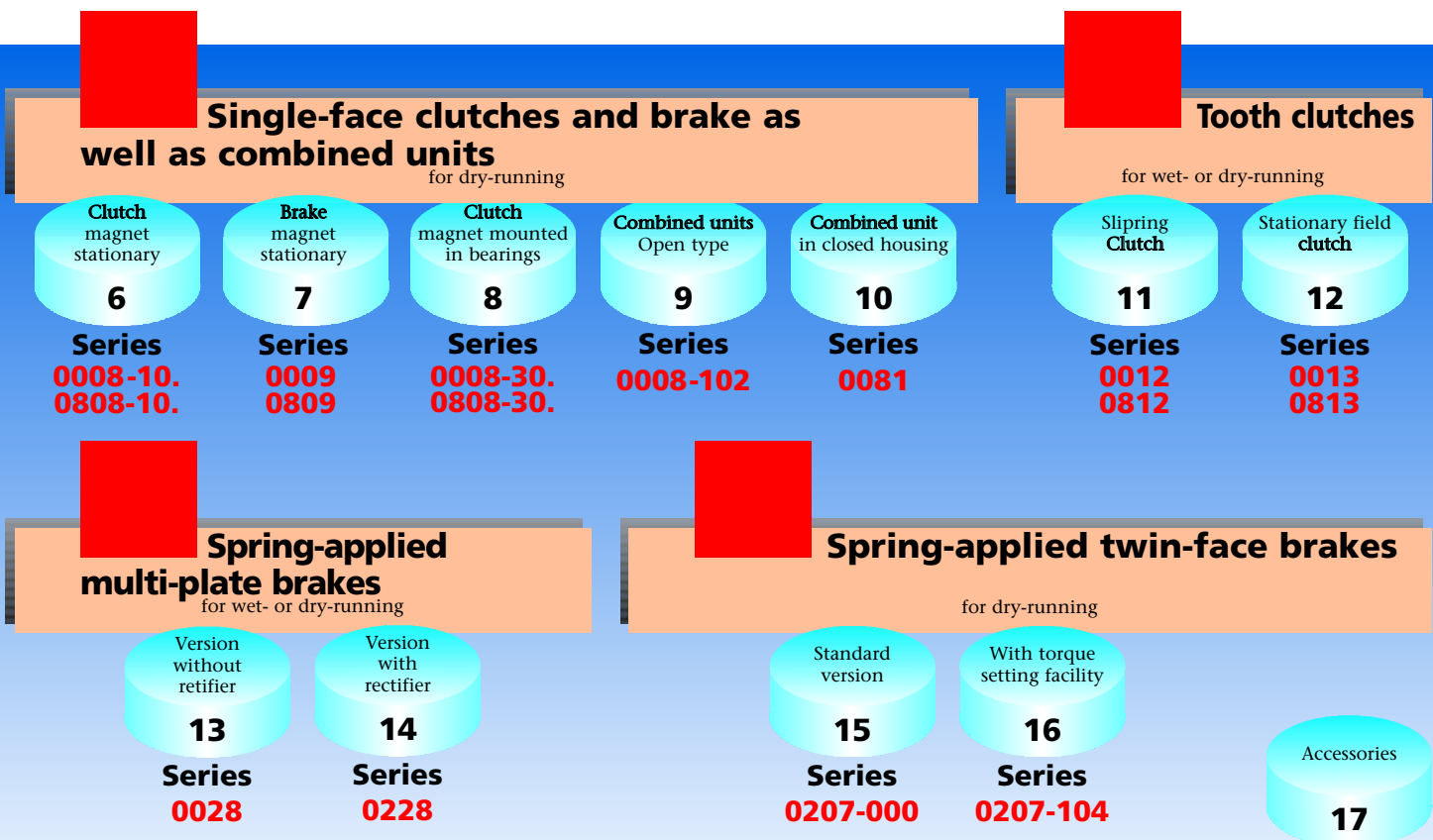

No.	Series	Torque range Nm	Hub bore mm	External diameter mm
1	0010	12 to 3000	18 to 98	80 to 310
	0810	12 to 290	18 to 60	80 to 166
2	0011-05.	12 to 3000	15 to 115	80 to 310
3	0011-100	12 to 3000	12 to 115	80 to 310
4	0011-300	12 to 1600	20 to 65	80 to 195
5	0006	12 to 2400	20 to 105	85 to 295
6	0008-10.	1,7 to 480	8 to 80	45 to 266
	0808-10.	1,7 to 480	8 to 80	45 to 266
7	0009	1,7 to 480	8 to 80	42 to 250
	0809	1,7 to 480	8 to 80	42 to 250
8	0008-30.	7,5 to 480	15 to 80	68 to 266
	0808-30.	1,7 to 480	15 to 80	68 to 266
9	0008-102	7,5 to 480	15 to 80	80 to 290
10	0081	7,5 to 120	14* to 40	120 to 250
11	0012	40 to 4000	20 to 98	70 to 240
	0812	100 to 1200	12 to 70	82 to 166
12	0013	40 to 1600	20 to 65	80 to 195
	0813	50 to 1000	20 to 60	82 to 166
13/14	0028/0228	7,5 to 600	16 to 80	100 to 250
15/16	0207	4 to 240	8 to 50	83 to 250

Friction lining: The single plate has organic friction linings on both sides.

Power feed: Via cables to the stationary magnet body.

17 Accessories

A comprehensive range of accessories are available for operating and controlling brakes and clutches.

We can supply

- Connection boxes.
- Rectifiers
- Plug-in connections/plugs
- Electronic load relays
- Power feeds
- Capacitors
- Brush holders
- Varistors

* Shaft journal

Application examples

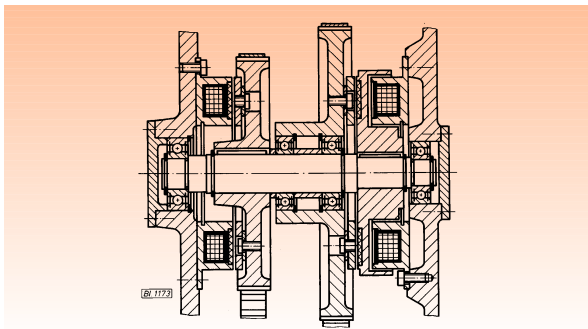

Electromagnetic single-face clutch, series **0-008-100**, here in combination with an electromagnetic single-face brake, series **0-009-100**.

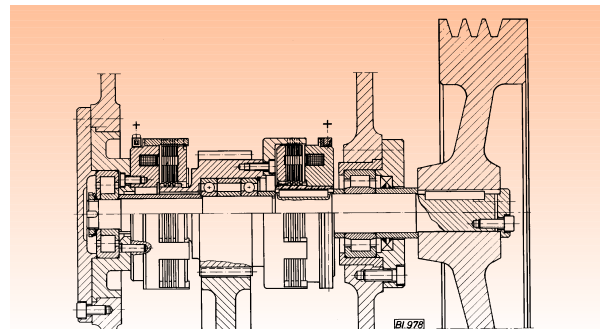

Electromagnetic Sinus® multi-plate clutch with slipping, series **0-011**, and electromagnetic Sinus® multi-plate brake, series **0-011-300**, as fitted in a straightening and cut-off machine.

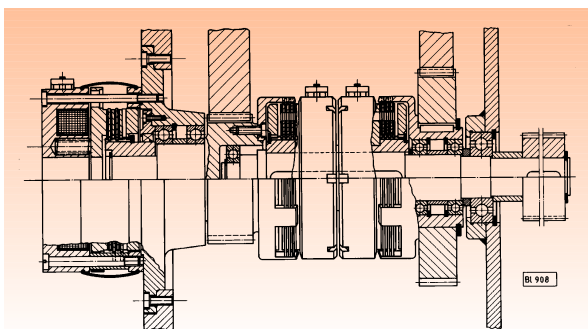

Stationary field electromagnetic Sinus® multi-plate clutches. Series **0-010**, friction combination steel/steel, here in combination with an electromagnetic, spring-applied multi-plate brake, series **0-028**, friction combination steel/"Ortex" friction lining, as fitted in winch drives.

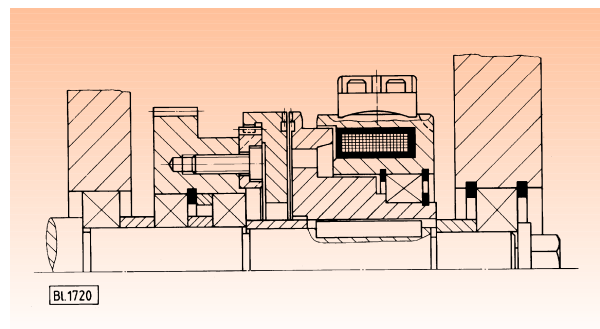

Stationary field electromagnetic tooth clutch, series **0-013** with the tooth wheel flanged onto the driving part.